

## Przeguby widełkowe DIN 71752

Opis artykułu/ilustracje produktu



### Opis

**Materiał:**  
Stal automatowa.

**Wersja:**  
Ocynkowane.

### Rysunki

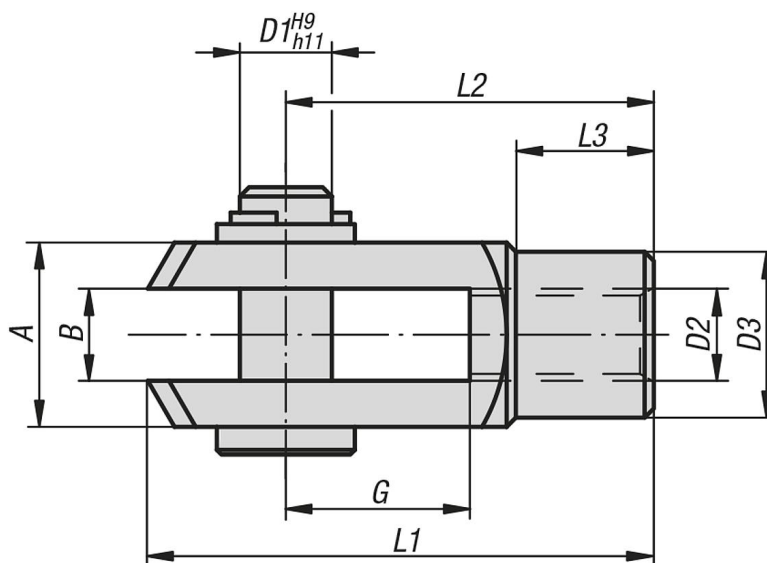

### Przegląd artykułów

#### Przeguby widełkowe DIN 71752

Nr Zamówienia	Wersja 2	B	G	D1	D2	D3	L1	L2	L3	A
K0733.0510	gwint prawy	5	10	5	M5	9	26	20	7,5	10
K0733.0612	gwint prawy	6	12	6	M6	10	31	24	9	12
K0733.0816	gwint prawy	8	16	8	M8	14	42	32	12	16
K0733.0832	gwint prawy	8	32	8	M8	14	58	48	12	16
K0733.1020	gwint prawy	10	20	10	M10	18	52	40	15	20
K0733.10120	gwint prawy	10	20	10	M10x1,25	18	52	40	15	20
K0733.1040	gwint prawy	10	40	10	M10	18	72	60	15	20
K0733.10140	gwint prawy	10	40	10	M10x1,25	18	72	60	15	20
K0733.1224	gwint prawy	12	24	12	M12	20	62	48	18	24
K0733.12124	gwint prawy	12	24	12	M12x1,25	20	62	48	18	24
K0733.1248	gwint prawy	12	48	12	M12	20	86	72	18	24
K0733.12148	gwint prawy	12	48	12	M12x1,25	20	86	72	18	24
K0733.1428	gwint prawy	14	28	14	M14	24	72	56	22,5	27
K0733.1632	gwint prawy	16	32	16	M16	26	83	64	24	32
K0733.16132	gwint prawy	16	32	16	M16x1,5	26	83	64	24	32
K0733.05101	gwint lewy	5	10	5	M5	9	26	20	7,5	10
K0733.06121	gwint lewy	6	12	6	M6	10	31	24	9	12
K0733.08161	gwint lewy	8	16	8	M8	14	42	32	12	16
K0733.10201	gwint lewy	10	20	10	M10	18	52	40	15	20
K0733.12241	gwint lewy	12	24	12	M12	20	62	48	18	24

## Przeguby widełkowe DIN 71752

### Przegląd artykułów

Nr Zamówienia	Wersja 2	B	G	D1	D2	D3	L1	L2	L3	A
K0733.16321	gwint lewy	16	32	16	M16	26	83	64	24	32